

# Internal standard sump system

## Specification

**Fans:** The most commonly used type of extract fan for a radon sump system is an in-line or other duct mounted centrifugal fan, which has an airtight casing. These are compact, quiet, widely available and can be easily fitted. However, there is no technical reason why other types of fan with similar air flow performance should not be used. Such fans are likely to have a flow rate of around 177m<sup>3</sup>/h at a pressure difference of 200 Pascals, and a power consumption of about 70 watts (check with your stockist as some manufacturers are introducing lower wattage fans).

**Fan wiring:** Fans should be wired in accordance with BS 7671: 2001 as amended, Requirements for Electrical Installations, the IEE Wiring Regulations.

## Suppliers of radon sump extract fans

A list of companies known to supply suitable fans is available from BRE.

**Pipework:** 110mm diameter uPVC pipe and fittings as used for domestic soil and vent pipes can be used. This is widely available from DIY stores and builders merchants.

**Sump construction:** The sump should be located close to the centre of the dwelling. It can be constructed using a paving slab 600 x 600 mm over a few rows of bricks with air gaps left between them, or by using a prefabricated sump. Details of suppliers of prefabricated sumps are available from the Radon Council Limited see overleaf.

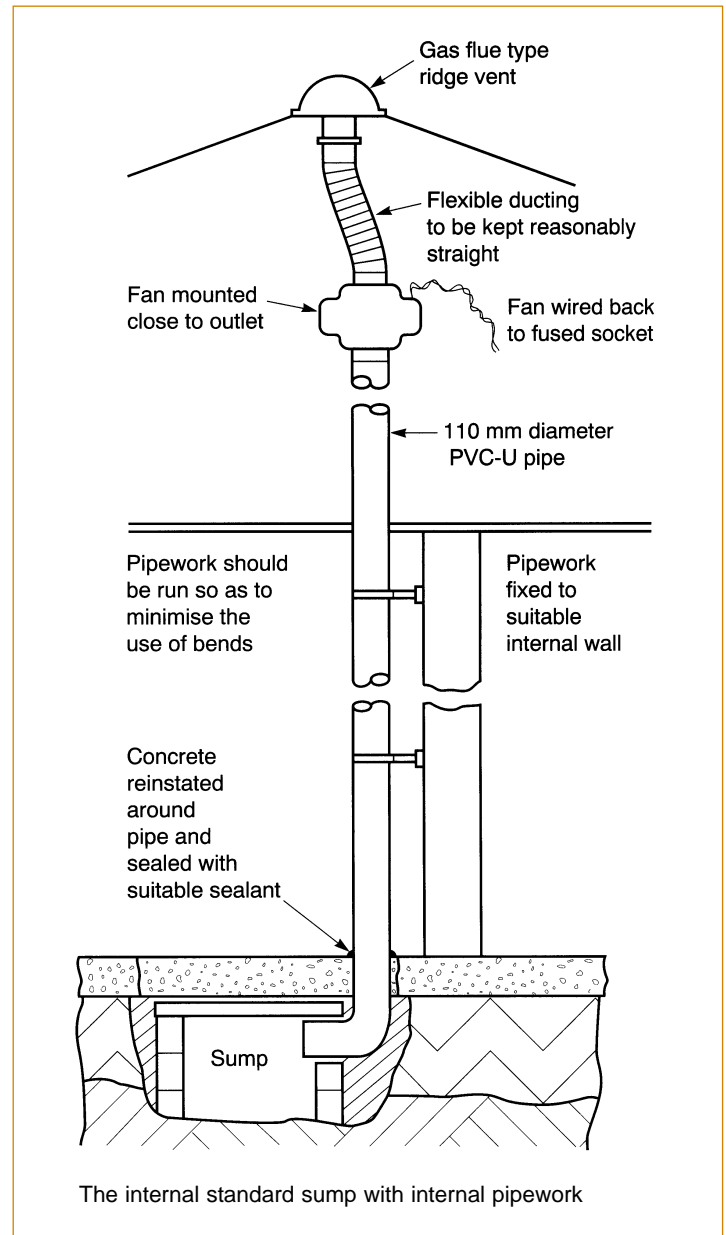

radon solutions



**Sealing:** It is important to seal around the pipework where it exits the floor slab to prevent air leakage. This can be achieved using a gun-applied bathroom sealant or similar, which can be obtained from a DIY store or builders merchants.

**Roof outlets:** The system can exhaust through a gas flue type ridge ventilator at the ridge (as shown) or through the slope of the roof via a vent cowl or tile vent. All are widely available from DIY stores and builders merchants.

### General points to consider

For a typical dwelling a single sump is likely to have an influence over an area of approximately

250m<sup>2</sup>, or for a distance approximately 15m from the sump. However, obstructions below the floor slab may reduce effectiveness. Because of a potential risk of spillage avoid locating a sump adjacent to an open flued combustion appliance such as an open fire or boiler which draws air from the room for combustion.

Care should be taken when breaking out to avoid damaging steel reinforcement or concealed services, e.g. electricity cables, water mains, central heating pipes and gas and oil supply pipes, similarly take care to avoid ceiling joists and any services in the roof space.

To reduce visual impact pipework can be routed inside a storey-height cupboard, or boxed-in in the corner of a room. Position the outlet well away from windows, doors and ventilation grilles.

To minimise noise keep pipework as straight as possible, and place the fan away from living rooms, bedrooms, or other quiet areas, but close to the outlet so that the pipework is always under suction. Do not support fans on lightweight walls or components that might transfer vibration to the rest of the property.

---

### Further information

More detailed guidance is available in BRE Report BR227 *Radon Sump Systems: a BRE guide to radon remedial measures in existing dwellings*, Good Building Guide 25 *Radon and Buildings* and Good Building Guide 26 *Minimising noise from domestic fan systems and fan-assisted radon mitigation systems* obtainable from BRE Bookshop, BRE Garston, Watford, WD25 9XX, telephone 01923 664262, e-mail [bookshop@bre.co.uk](mailto:bookshop@bre.co.uk), or visit [www.BREbookshop.com](http://www.BREbookshop.com)

- for further practical advice about work to reduce radon levels
- for a list of companies known to supply suitable fans

Contact BRE Radon Hotline 01923 664707 [www.bre.co.uk/radon](http://www.bre.co.uk/radon)

### Disclaimer

It should be noted that BRE cannot guarantee that the measures described on this sheet will reduce the radon level in your home, however similar measures have regularly proven successful elsewhere in the UK.

Prepared for The Department for Environment, Food and Rural Affairs.

Prepared by Building Research Establishment Ltd © Building Research Establishment Ltd 2003.

Printed on recycled paper containing 80% post consumer waste and 20% Totally Chlorine Free virgin pulp.

### Other useful contacts

Defra 020 7082 8498

[www.defra.gov.uk/environment/radioactivity/radon](http://www.defra.gov.uk/environment/radioactivity/radon)

NRPB 0800 614529 [www.nrpb.org/radon](http://www.nrpb.org/radon)

The Radon Council 01932 221212 [www.radonhotline.org](http://www.radonhotline.org)

PB8518b

