

General points to consider

A low level sump system can only be used where there is sufficient space around the exhaust outlet so as not to pose a risk to health. As a rule of thumb it is usually only appropriate where the exhaust is two or three metres from the nearest opening, doors, windows, or vents, there are no other buildings or regularly used spaces such as patios immediately adjacent, and the exhaust can be directed to discharge away from the building.

The advantages of this solution are that it offers the same level of effectiveness as a conventional sump system which exhausts at eaves level, but it is visually less obtrusive and requires less materials to construct. They are ideally suited for use in cases where planning restrictions do not allow changes to the external appearance of a property, e.g. Listed buildings, conservation areas, or National Parks.

For a typical dwelling a single sump is likely to have an influence over an area of approximately 250 m², or for a distance of approximately 15 m from the sump. However, obstructions below the floor slab may reduce effectiveness. Care should be taken to avoid locating the sump near to an open flued

appliance such as an open fire or boiler drawing air from a room to prevent the risk of spillage. To minimise noise the fan should be placed as far from occupied rooms as possible.

Care should be taken when breaking out to avoid damaging steel reinforcement or concealed services such as electricity cables or water pipes.

Suppliers of radon sump extract fans

A list of fan manufacturers known to produce fans suitable for use with radon sump systems is available from BRE. Many fan manufacturers, as well as wholesalers and local distributors are also listed in local business telephone directories.

The Radon Council maintains a list of contractors, suppliers and consultants offering advice and services involving remedial works for radon gas, many of whom can supply fans. Details can be obtained from the Radon Council Limited, PO Box 39, Shepperton, Middlesex, TW17 8AD, Tel: 01932 221212, Fax:01932 229779. Trade associations may also be able to help – details of these can often be found in main libraries.

Further information

More detailed guidance is available in BRE Report BR227 *Radon Sump Systems: a BRE guide to radon remedial measures in existing dwellings*, and Good Building Guide 26 *Minimising noise from domestic fan systems and fan-assisted radon mitigation systems* obtainable from BRE Bookshop, BRE Garston, Watford, WD25 9XX, telephone 01923 664262, e-mail bookshop@bre.co.uk, or visit www.BREbookshop.com

For further practical advice about work to reduce radon levels is available from the BRE Radon Hotline 01923 664707

Prepared for The Department for Environment, Food and Rural Affairs.
Prepared by Building Research Establishment Ltd © Building Research Establishment Ltd 2003.
Printed on recycled paper containing 80% post consumer waste and 20% Totally Chlorine Free virgin pulp.

Other useful contacts

Defra 020 7082 8498
www.defra.gov.uk/environment/radioactivity/radon
NRPB 0800 614529 www.nrpb.org/radon
The Radon Council 01932 221212 www.radonhotline.org
PB8518r



radon solutions

Sump systems

Specification

Fans: The most commonly used type of fan for a radon sump system is an in-line or other duct mounted centrifugal fan, which has an airtight casing. These are compact, quiet, and widely available and can be easily fitted. However, there is no technical reason why other types of fan with similar air-flow performance should not be used. Such fans are likely to have a flow rate of around 177 m³/h at a pressure difference of 200 Pascals, and a power consumption of about 70 Watts.

Where a fan is to be exposed to weather it should be of a type that is suitably protected. It will need to be protected to level IP54 as classified in BS 5490. The fan manufacturer or supplier should be able to confirm that the chosen fan complies with this requirement. If the fan does not meet this level of protection the fan will need to be mounted within a suitable weatherproof housing.

Where a fan is fixed externally to a house wall as shown here, it may be connected to an existing ring circuit through a fused connection unit with a double pole switch. If the fan is remote from the house,

it must be on its own Residual Current Device RCD-protected circuit running from the consumer unit and capable of isolation by means of a double pole switch.

Pipework: 110 mm diameter uPVC pipe and fittings as used for domestic soil and vent pipes can be used. This is widely available from DIY stores and builders merchants. The fan connections are typically 150 mm in diameter so a 150 mm to 110 mm reducer will be needed to join the pipe to the fan.

Sump construction: A simple mini sump can be constructed by breaking out or core drilling a 120 mm diameter hole through the external wall just below the floor slab and excavating about a

bucketful of material (clearing out a space of approximately 200 mm in radius).

Sealing: it is important to seal around the pipe-work where it exits the floor slab to prevent air leakage. This can be achieved using a gun applied bathroom sealant or similar, which can be obtained from a DIY store or builders merchants.

radon solutions



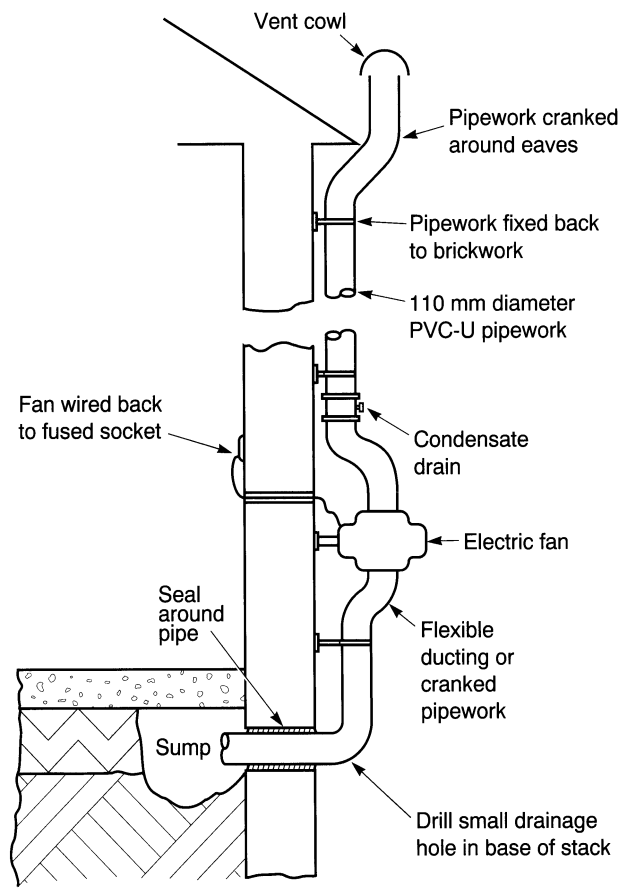

The externally excavated sump

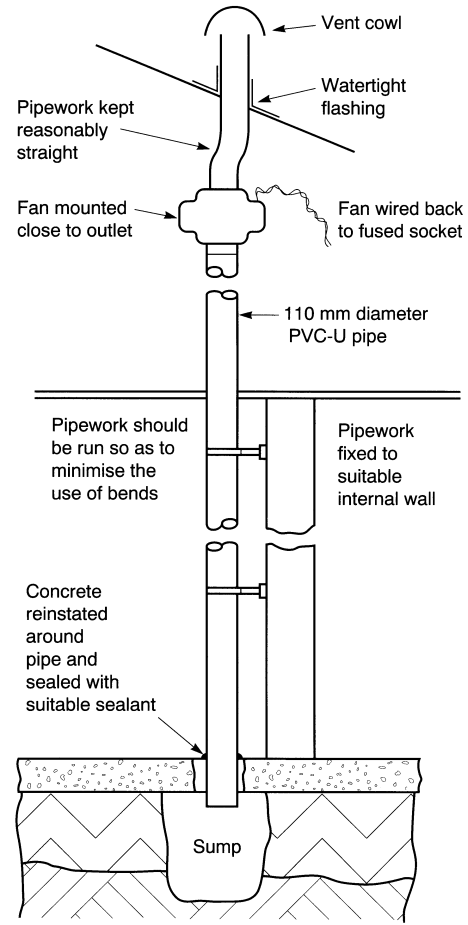

The internal mini sump system with internal pipework

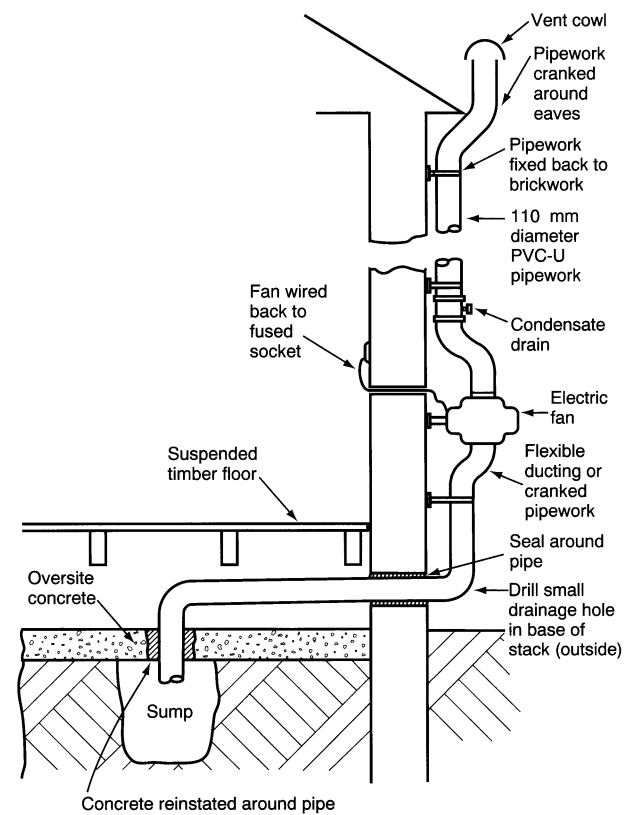

Sump installation beneath suspended timber floor

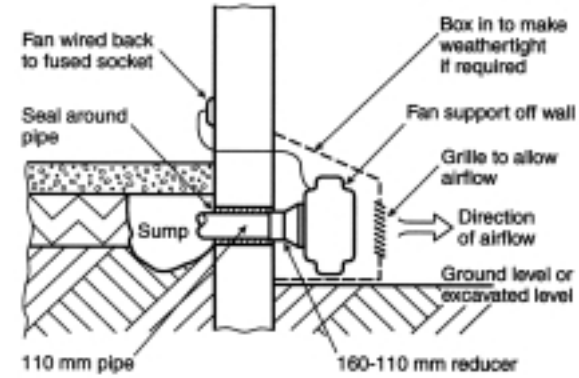

Externally excavated mini sump with low level exhaust

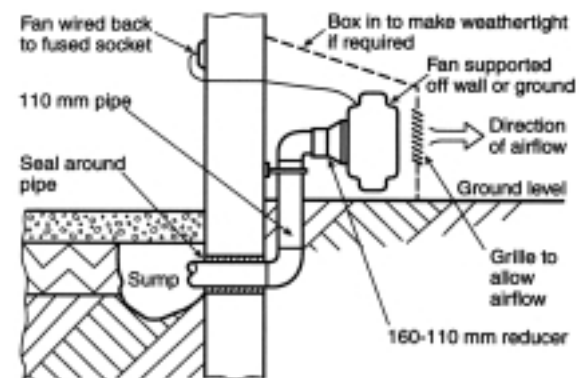

Alternate design of sump system

To improve appearance 67¹/₂° bends are shown at the eaves (these are also called eaves offset bends)

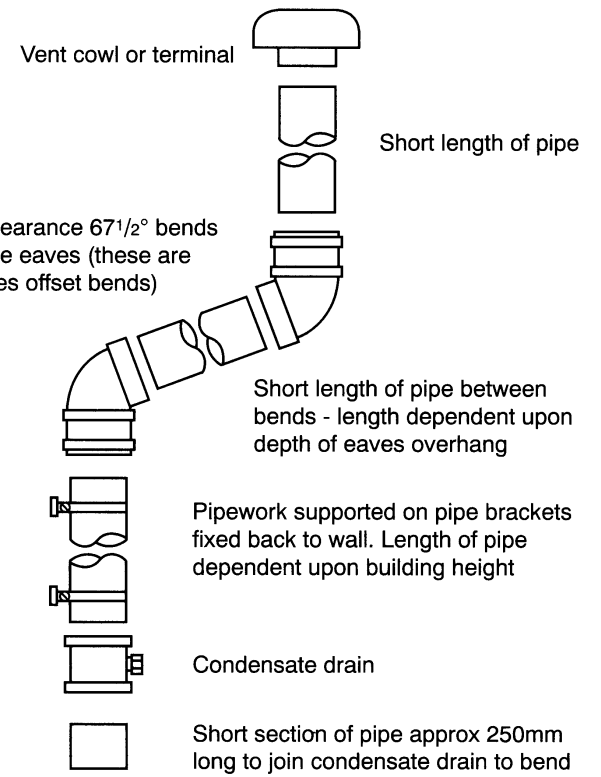

45° short radius bends

Rubber adaptor couplings used to join 110mm diameter pipe to 150mm fan connection. Plastic adaptors can also be used. Plastic is usually cheaper and easier to obtain locally, but rubber helps reduce vibration noise caused by the fan

Electric fan supported on wall bracket and wired back to fused socket inside the building - keep the fan low down the wall so that it can be boxed-in

If accessible seal joint between floor and wall close to sump to minimise suction from room.

Short section of pipe - keep short if the fan is to be boxed-in

87¹/₂° short radius bend

Short length of pipe laid 50mm into sump. When joined to short radius bend will slope down 2¹/₂° into sump. Seal well around pipe where it passes through the wall to ensure that air cannot be drawn from around the pipe

Sump constructed by excavating about a bucket full of the material from beneath the edge of the floor. All excavation work is carried out from outside of the building